

PNW574

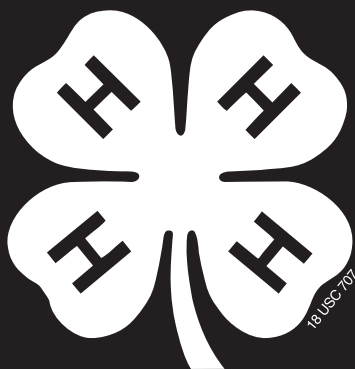

# 4-H Horse Contest Guide

A Pacific Northwest Extension Publication  
Washington State University • Oregon State University • University of Idaho

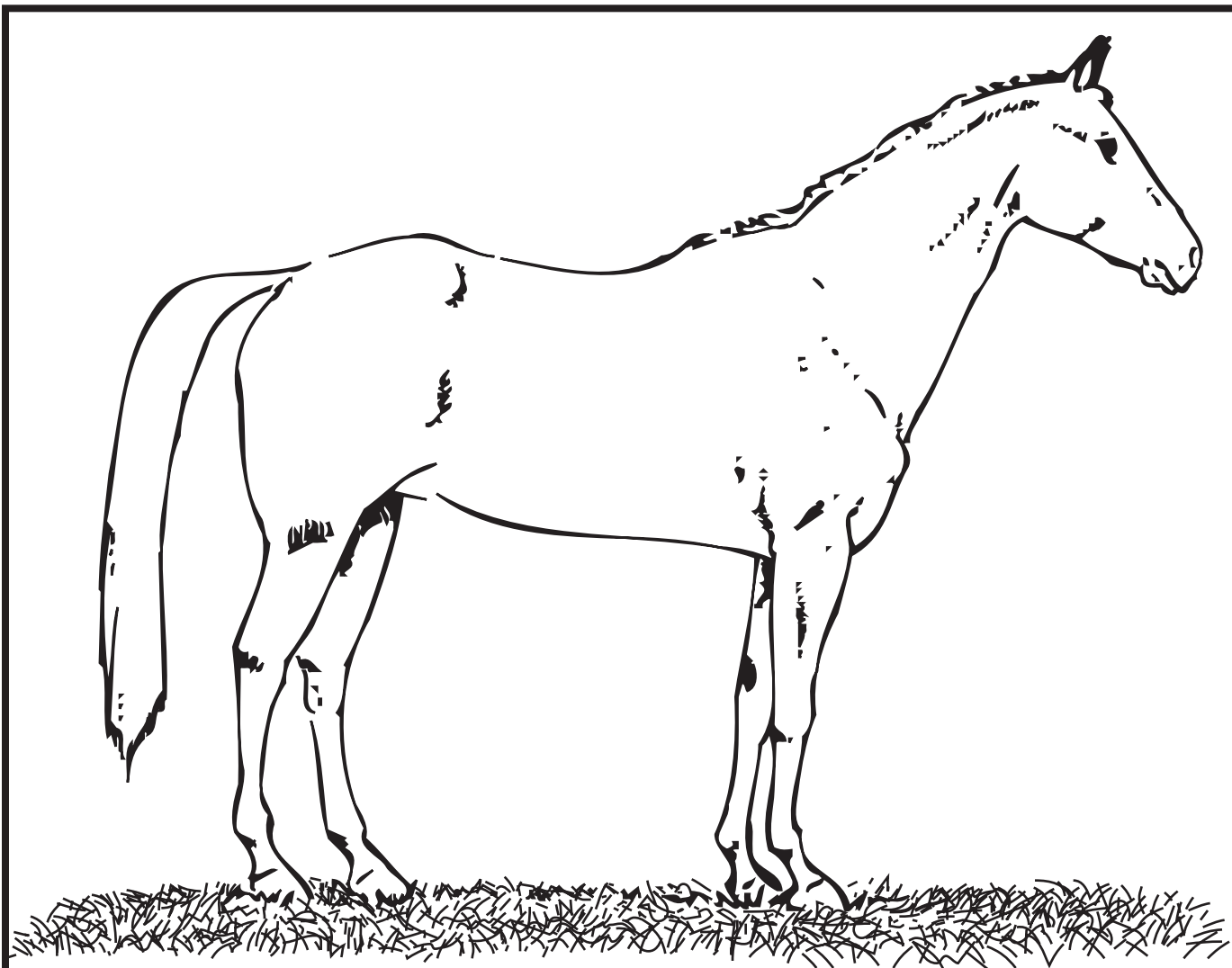

Effective October 1, 2009 through September 30, 2011

Revised by the Oregon/Washington/Idaho 4-H Horse Curriculum Team.

Oregon members are Roberta Lundeberg, 4-H State Program Coordinator; Candi Bothum, 4-H County Program Coordinator; and Peggy Ashford, 4-H volunteer.

Washington faculty members are Jennifer Leach, Interim 4-H Equine Specialist; and Jerry Newman, Extension 4-H Youth Development Specialist

Idaho faculty/staff members are Carrie Stark, 4-H Youth Development Specialist; Jim Wilson, Area 4-H Youth Extension Educator; and Erika Thiel, 4-H Program Coordinator

Originally adapted (2005) from EB1974 by Candi Bothum, 4-H County Program Coordinator; Roberta Lundeberg, 4-H State Program Coordinator; Shirley Watson, 4-H Program Assistant (retired); and Peggy Ashford, 4-H volunteer, all of Oregon State University; and Jerry Newman, Extension 4-H Youth Development Specialist; Marilyn Anderson, Anne Garrett, Doug Evenson, and Pat Pehling, all 4-H volunteers, all of Washington State University

For corrections or changes to this publication, contact:

In Idaho—

University of Idaho, 4-H Youth Development  
PO Box 443015  
Cont. Education Building, 206, Moscow ID 83844  
Phone: 208/885-2156 FAX: 208/885-4637

In Oregon—

Oregon State University, 4-H Youth Development State Office  
105 Ballard Extension Hall, Corvallis OR 97331-3608  
Phone: 541/737-9295 FAX: 541/737-1332

In Washington—

Washington State University, 4-H Youth Development State Equine Advisory Committee  
ATTN: Jennifer Leach, Interim 4-H Equine Specialist, 1946 3rd Ave. Longview, WA 98632  
Phone: 360/577-3014 ext. 4 FAX: 360/423-9986

Any corrections or changes must be sent and approved by the appropriate horse development or equine advisory committee. Approved changes will be forwarded to the Pacific Northwest (PNW) horse management team for review and final decision.

# 4-H Horse Contest Guide

---

These contest rules are 4-H policy for Washington and Oregon 4-H horse programs and being reviewed for implementation in Idaho. 4-H events are provided for under the auspices of state land grant universities. All members, leaders, parents, and judges should be aware of these rules when participating in 4-H activities, and it is expected that these rules be observed.

This contest guide contains general rules and guidelines for competitive activities in the 4-H horse program. Contests help youth measure progress in knowledge and skill in horsemanship. They also provide opportunities to learn social skills and have fun.

Counties are bound by state rules, but may be more restrictive. Counties should create rules and criteria for “county only” classes not addressed in this guide. This makes it easier for leaders to teach and judges to evaluate a member’s performance.

Failure to abide by rules in the *4-H Horse Contest Guide* may result in dismissal from the show and/or forfeiture of all awards. In addition, any gross abuse of these rules could result in the removal of a 4-H member from the 4-H program.

In addition to this guide and information provided by local show committees, several support publications are available. 4-H members, leaders, and parents are strongly encouraged to read the following 4-H horse manuals **before** using this contest guide to better understand the terminology and context of the information provided here. Additional resources are listed for those interested in related activities and opportunities. If any discrepancies exist between sources, **this contest guide takes precedence over all other material.**

## PNW Resources

- *4-H Driving Manual*, PNW 229
- *4-H Hunt Seat and Jumping Manual*, PNW 488
- *4-H Horse Judging Manual*, PNW 575
- *4-H Horse Project Manual*, PNW 587
- *4-H Dressage Manual*, PNW 608

## Oregon Resources

- *E.L. “Dad” Potter 4-H Horsemanship Award*, 4-H 1302
- *4-H Colt and Horse Training Manual*, 4-H 1303

## Washington Resources

- *Horse Conformation Analysis*, EB 1613
- *Beginning Horsemanship*, EM 4842

Members who wish to participate in open or breed shows should check appropriate show rules for tack, dress, and performance requirements.



# Contents

<b>Mission</b> .....	1
<b>General Rules</b> .....	1
Show Protocol .....	2
Competition Divisions .....	2
Approaching the Judge .....	3
Drugging .....	3
Volunteer Policy on Animal Disease .....	4
Project Animal .....	4
Possession .....	4
Replacement .....	5
Horseless Horse Project .....	5
<b>Clothing &amp; Equipment</b> .....	5
Western .....	6
Hunt Seat and Dressage .....	8
Saddle Seat .....	9
<b>Contest Guidelines</b> .....	10
<b>Performance Guidelines</b> .....	11
Showmanship .....	11
Equitation .....	14
Bareback Equitation .....	15
Hunt Seat Equitation over Fences .....	15
Dressage .....	17
Trail .....	17
<b>Driving</b> .....	19
Appointments .....	19
Classes .....	20
<b>“Dad” Potter Award</b> .....	24
<b>Washington State Medals Program</b> .....	27
<b>Ground Training</b> .....	28
<b>Western Games</b> .....	29
<b>Herdsmanship</b> .....	40



## **Mission**

As part of the 4-H youth development program, our mission is to use horses as the vehicle for members to practice life skills while learning about the equine industry and how to safely handle, ride, and manage their 4-H horse project.

**4-H Motto:** To Make the Best Better

### **4-H Pledge:**

I pledge my HEAD to clearer thinking,  
My HEART to greater loyalty,  
My HANDS to larger service,  
And my HEALTH to better living  
For my club, my community, my country, and my world.

## **General Rules**

1. Only 4-H members may ride, groom, school, or handle a horse while on the show grounds. Junior members may have assistance with saddling and bridling if needed. Anyone may have assistance for safety reasons.
2. No one is allowed to coach contestants while the contestants are in the show ring.
3. A horse not under control may be dismissed from the ring.
4. A visibly ill or unsound animal may be dismissed from participation by show personnel or at the judge's discretion.
5. The humane treatment of all animals is required. Exhibitors are expected to treat their animals with respect and to provide for their continuous well-being through proper feeding, handling, disease prevention, sanitation, and attention to safety.
6. Horse may not be ridden double at any time.
7. Horses may not be ridden with halters only.
8. The arena is off-limits to everyone except working show personnel or during an emergency.
9. Judges' decisions are final.
10. Approach the judge for information only, not to dispute placings, and only after judging is completed.
11. Show management or the judge reserves the right to dismiss any youth or party from any 4-H class or show for any misconduct, lack of sportsmanship, or infractions of the rules. Exhibitors may forfeit all awards received in the class or at the show.
12. County committees may make accommodations for special circumstances at county 4-H events. State committees may decide if county accommodations are eligible for respective state 4-H events.

## Show Protocol

1. Members should be courteous and alert and follow instructions given by the judge or ring steward, including entering promptly when a class is called.
2. Contestant numbers must be clearly visible either on the rider's back or on both sides of the saddle pad. (The exhibitor is responsible for supplying the second number.)
3. If a "gate hold" (delay of class) is necessary for equipment change, this should be requested before the class is called. Unnecessary delays may be penalized.
4. A red ribbon on the tail denotes a horse that may kick if crowded.
5. Attitude is scored. Exhibitors should show confidence and pride in themselves and their animals. They should be good sports. Contestants are being judged at all times when they are in the ring.
6. Special needs youth and/or anyone needing assistance will ride last (at the end of a class) so members following them will not benefit more than members who rode before them.
7. In 4-H, equitation classes are judged on the skill of the rider. The horse is not judged on conformation.
8. When a judge requests a movement to the right (off-side) or left (near-side), this is to the horse's right or left.
9. Exhibitors should not pat their horse while being judged in the ring, except during a colt or ground training class.

## Competition Divisions

Idaho (ages as of January 1)

Junior: 8–11 year olds

Intermediate: 12–14 year olds

Senior: 15–18 year olds, or still in high school

Oregon

Junior: 4th, 5th, and 6th grade

Intermediate: 7th, 8th, and 9th grade

Senior: 10th, 11th, and 12th grade or 12th grade equivalent

Washington Youth in the 3rd grade who have reached their 8th birthday by January 1 of the current 4-H year are eligible to enroll.

Junior: 3rd, 4th, and 5th grade

Intermediate: 6th, 7th, and 8th grade

Senior: 9th, 10th, 11th, and 12th grade

Youth who have reached their 19th birthday before January 1 of the current 4-H year are no longer eligible for membership.

### **Inter-Age Competition Statement**

Washington State does not allow inter-age competition. For example, juniors may not compete against intermediates, or intermediates against seniors.

## Approaching the Judge

### **Exhibitor**

While the judge's decision is final, every exhibitor (parent or leader may be present), for educational purposes, should have an opportunity to approach or ask questions of a judge. The exhibitor should not approach the judge until after the final class of the day, or as otherwise specified by the show committee. The contestant should provide their exhibitor number and any score sheets they may have received, but photos or videos are not allowed. The contestant should expect discussion or explanation on how to improve.

### **Show Committee**

It is the show committee's responsibility to provide an opportunity for exhibitors to approach judges. This information will be relayed to exhibitors during the informational meeting or by other means. Before the beginning of a class or show, questions about specific classes or rules need to be addressed to ALL exhibitors, not one-to-one. Show committees need to remember that judges' decisions are final.

### **Judge**

The judge should confirm with the show committee or superintendent when questions may be asked and answered and when an exhibitor may approach the judge. Since judges' decisions are final, they should expect their decisions to be upheld. A judge should be able to provide oral or written comments or clarification to an exhibitor when asked. Judges must address questions about specific classes or rules to ALL exhibitors, not in a one-to-one setting.

### **Recourse**

Judges' decisions are final. A show committee has the recourse to not rehire a judge who has not met their expectations. Concerns regarding judges who do not meet 4-H standards can be addressed to the PNW judges' list coordinator and the PNW judges' review committee. Evaluation forms are available on the Web or at your county Extension office. The coordinator and committee will investigate any concerns and make an appropriate response to the judge.

## Drugging

The 4-H horse program does not condone the use of drugs, herbal compounds, or surgical procedures which affect an animal's conformation, appearance, natural performance, or in any way alters its natural color. Horses requiring any medication should be identified upon arrival at the 4-H Horse Show Office or registration area. Exhibitors should be prepared to present a valid prescription or a written explanation, either or both to be signed by the animal's licensed veterinarian. If a horse requires medication or treatment after arrival at the show, any medication used to protect the health and welfare of the animal must be prescribed by a licensed veterinarian. Administration of all medication must, at all times, be done in accordance with the specification and/or instructions given in the prescription. Liability for the correct administration of the prescribed drug is the responsibility of the exhibitor's parent or legal guardian.

## **Volunteer Policy on Animal Disease Diagnosis & Treatment**

4-H volunteers, as representatives of a land grant university, are expected to act within the policies and guidelines of the 4-H youth development program. A 4-H animal science volunteer may educate members and their families in the normal course of their 4-H activities in the areas of animal care, production, and management. University volunteers are NOT to engage in activities that include the diagnosis or treatment of or the direct administration of medications to protect animals without authorization from a licensed veterinarian. A 4-H volunteer may exercise commonly accepted first-aid skills/practices in emergency situations.

### **Project Animal**

Each member is expected to have access to one or more horses which may be owned, shared, or leased.

A shared project animal is defined as only immediate family members or 2 non-family members sharing the same horse, including care and training responsibilities. Members and parents must recognize that adjustments and/or choices may need to be made to adapt to show conditions or schedules, such as when 2 members are in the same class or are competing for championships.

A lease agreement is permissible if the member provides primary care for the horse. States or counties may require that a copy of the lease be included in the member's record book.

The horse shown in a 4-H exhibit activity must be the member's project horse. To participate at state fair, an exhibitor must use the same horse that was exhibited at the county fair. Stallions older than 12 months are NOT allowed in 4-H contests or events.

Horses should be clean and well-groomed, with the feet trimmed or shod. Fetlocks, muzzle, and bridle path should be trimmed according to breed type. The mane and tail may be long or braided. If the tail is braided, the entire mane must be braided. If the mane is braided, braiding of the tail is optional. Exhibitors may not decorate their horse with glitter, paint, or other means except in western gaming.

To be classified as a pony, the animal must be 56" in height or less. When there are a great number of ponies, they may be divided into small pony and large pony divisions:

Small pony: any pony less than 48" in height

Large pony: any pony 48–56" in height

When there are few ponies, counties have the option of combining horse and pony classes.

### **Possession**

The goal of 4-H is to ensure that youth have opportunities within the four Essential Elements of the 4-H Youth Development Program [belonging, mastery, independence, and generosity]. Projects are used as tools to promote positive youth development. The purpose

of 4-H events is for 4-H members to demonstrate what they have accomplished with their projects during the year. The goals of the 4-H program are only met if the accomplishments demonstrated are the result of the 4-H member's own work. Therefore, project animals (owned, leased, or shared) must be under the care and management of the 4-H member at least 90 days before the animal may be shown at the official county exhibit activity.

In **Oregon**, only the 4-H member participating in the contest can train their animal 90 days prior to the county or state fair.

In **Washington** and **Idaho**, only the 4-H member(s) can personally train their animal 90 days prior to the county-designated event and state fair.

## Replacement

Counties have the option to use an appeal board or variance committee process to determine if the animal in question can be replaced in the case of death or severe injury. A successful appeal may show at the county level, but will not be allowed to exhibit at state fair.

## Horseless Horse Project

A youth may choose to enroll in the Horseless Horse project. Primary members (grades K-2 in **Washington**) or Adventures (K-3 in **Oregon**) may also enroll in the Horseless Horse project, but may have NO contact with horses.

In **Idaho**, a "non-horse" project is available for interested youth who do not have access to a project animal.

## Clothing & Equipment

Members and attendants should be neat, clean, and dressed with hard-soled shoes or boots, long-sleeved shirts, and long pants. Boots are required for exhibitors in all classes. Boots are defined as high-topped (above the ankle) leather or leather-like riding shoes with heels. The boot must have an adequate heel to prevent it from moving forward through the stirrup. Exhibitors must be able to slide their boots out and move them freely in the stirrup.

Equipment must be safe, clean, properly adjusted, and suitable for the class being shown. An exhibitor's hair must be worn in a net, braid(s), or other means to present a neat appearance and a clear view of the show number.

Each member must have proper clothing and equipment for the specific classes entered (refer to the appropriate divisions). Variations in clothing and/or tack (including bandages on the horse) are permitted if there is a valid medical reason. However, a letter explaining the need for the variation, signed by the physician and/or veterinarian, must be presented to the show managers prior to the start of the show.

## The 4-H Equestrian Headgear Policy

4-H members participating in any 4-H equestrian activity must wear an approved helmet whenever they are mounted on an equine or are in a vehicle (cart, wagon, buggy, etc.) being pulled by an equine. An approved helmet meets the minimum performance standards imposed by the American Society for Testing Materials (ASTM) F1163 and includes certification and labeling required by the Safety Equipment Institute (SEI). The helmet must be properly fitted with the harness engaged and properly fastened. It is recommended that 4-H'ers wear their ASTM/SEI helmets any time they are around their horse.

### Western

Western clothing and equipment is appropriate in western classes including, but not limited to, trail, western equitation, showmanship, ground training, driving, and bareback.

#### *Required:*

- Long-sleeved western shirt with collar, tucked in and sleeves rolled down
- Jeans, trousers, or western pants
- Belt, unless loops are covered with another garment (except in western games)
- Western boots
- ASTM/SEI equestrian-approved helmet

#### *Optional:*

- Vest, jacket, coat, sweater, and/or jacket with collar
- Gloves
- Ties, pins
- Chaps in pleasure and trail only

#### *Not allowed:*

- Chaps in showmanship or equitation
- Whips or crops, except in western games
- Spurs in showmanship or driving

### **Saddle & Pad**

Any standard western saddle with a horn may be used, but it must fit the rider and the horse. If a back cinch is used, it should be adjusted close to the horse and attached to the front cinch with a connecting strap. If the cinch pin is not being used, it should be removed. Any clean saddle pad, blanket, or combination is allowed if it provides sufficient padding for horse and rider. Silver is not to be given preference by the judge. Tapaderos (stirrup covers) are not allowed.

### **Bridle**

Any western bridle (including snaffles and bosals) that includes a curb strap or curb chain may be used. This includes bridles with throat latches and split-ear bridles. Sidepulls are not allowed in performance classes. Throat latches on all bridles are strongly recommend-

ed for safety purposes. Cavessons or nosebands are not allowed in performance classes. Refer to the Western Games section for gaming bridle criteria.

Only split or romal reins are allowed in western equitation, trail, and bareback. Single piece closed reins or "roping reins" are **required** in western gaming.

Only one hand may be used for reining when using a western bit with shanks for western equitation, trail, and bareback. The rein hand cannot be changed.

When romal reins are used, no finger between the reins is allowed. In these cases, the romal goes on the opposite side from the rein hand.

When split reins are used with a curb, the rider may use a finger between the reins, but the bight of the reins must remain on the same side as the rein hand, and the ends are not held. Palm should be down. The position of the hand not used for reining is optional, but it should be kept free from the horse and saddle and held in a relaxed manner.

When the ends are held with split reins and a curb, there are no fingers allowed between the reins. The ends of the reins are usually held on the rider's thigh with about 16" of rein between the 2 hands as if holding a romal.

When a bosal or snaffle bit is used, 2 hands must be used. Split reins should be held by crossing the reins between hands so that both hands are holding both reins. Closed reins are allowed with a bosal.

To mount with romal reins, double the end in the left hand. After mounting, slide the bight under the rein hand to the opposite side. For a brief dismount, romal reins need not be taken down; the romal part may be looped behind the horn. Both split reins, or the near rein only, may be taken down. Never let go of the reins.

## **Bit**

Most types of western bits are acceptable. Mechanical hackamores, double wire snaffles, slip, or gag bits are NOT allowed, except in western games. Overall bit length, as measured in the picture below, can be no longer than 8½." Curb straps must be plain leather or chains at least ½" wide, and must lie flat against the jaw. Rolled leather straps are unacceptable. Refer to the Western Games section for gaming bit criteria.



The correct measure of overall bit length is a vertical line from the upper-most part of headstall slot to the center of the rein ring.

Horses 5 years of age or younger may be ridden in a snaffle or bosal. For horses 6 years old or more, a curb bit is highly preferred. Members showing horses 6 or older in a snaffle or bosal must have a performance significantly better than a member showing a 6-year-old or older horse in a curb bit to be placed above them.

Horses 6 and older shown in a snaffle or bosal may be ineligible for top county awards (at local discretion). In **Washington**, such horses shall be ineligible to advance to state 4-H competitions. In **Idaho**, such horses shall be ineligible to advance to district, regional, or state 4-H competitions. In **Oregon**, these horses are eligible for the state fair.

Misrepresentation/falsification of a horse's age is grounds for immediate disqualification of that exhibitor from the 4-H event and subsequent disciplinary action by local Extension personnel up to or including dismissal from the 4-H program.

### **Optional Tack and Equipment**

Hobbles, a lariat or riata, and breast collars are optional. Spurs, if worn, must be used properly and western type. Tie-downs, martingales, draw-reins, nosebands, splint boots, bell boots, bandages, etc., are NOT allowed, except in western games. Splint boots, bell boots, and other protective gear may be allowed in medal, green horse, or other county classes.

## **Hunt Seat & Dressage**

Hunt seat or dressage equipment and clothing may be used appropriately in showmanship, driving, hunt seat equitation, equitation over fences, trail, ground training, dressage, and bareback.

### ***Required:***

- Ratcatcher, long-sleeved tailored shirt, or a turtleneck (shirts tucked in and closed at the neck)
- Hunt coat if short-sleeved ratcatcher is worn
- Pants, breeches, or jodhpurs
- Tall hunt boots or jodhpur boots
- ASTM/SEI equestrian-approved helmet

### ***Optional:***

- Hunt coat (conservative colors)
- Spurs, if used, must be English type and used appropriately. In dressage, rowels must be free to rotate
- Half-chaps
- Gloves (any traditional color allowed)

### ***Not allowed:***

- Spurs in showmanship or driving

### **Saddle**

The type of English saddle used is optional; however, a saddle seat-type English saddle or a western saddle is prohibited. Stirrup safety bars must be in the open position in equitation over fences.

## **Bridle & Bit**

An English bridle with cavesson is required. Sidepulls and bit converters are not allowed. A snaffle, pelham, kimberwick, full double bridle, or any other English-type bit appropriate for the seat may be used. Double twisted wire and gag bits are not allowed.

Dropped, flash, and figure-8 nosebands are allowed in dressage and hunt seat equitation over fences, but no other flat classes.

## **Optional**

Breastplates or breast collars and saddle pads are optional. Martingales and any type of boots are not permitted in flat classes but are allowed in equitation over fences. Whips or crops may be no longer than 36" for hunt seat.

## **Specific to Dressage**

An English bridle made entirely of leather or leather-like material (except for buckles) is mandatory. In Intro.–2nd levels, a plain smooth snaffle bit is required. For appropriate bits for 3rd level and up, refer to USEF dressage rules. See the *4-H Dressage Manual*, PNW608, for types of acceptable bits. The mouthpiece of any bit must be metal or rigid plastic and may be covered with rubber. Flexible rubber bits are not permitted. Whips or crops may be no longer than 48" for dressage.

Strictly forbidden, under penalty of elimination, are martingales, bit guards, accessories (bearing, side, running, or balancing reins), any type of boots (including "easy boots"), bandages, any form of blinkers, ear muffs or plugs, nose covers, seat covers, and hoods.

## **Saddle Seat**

Saddle seat equipment and clothing may be used appropriately in showmanship, saddle seat equitation, trail, ground training, bareback, and driving.

### ***Required:***

- Long-sleeved tailored shirt, or short-sleeved shirt if wearing a coat
- Tie
- Jodhpur boots (short)
- ASTM/SEI equestrian-approved helmet
- Pants or Kentucky jodhpurs

### ***Optional:***

- Saddle suit may be worn, but must be of conservative colors and will not be given preference by the judge
- Spurs, if used, must be English type and in mounted classes only
- Whip no longer than 48," including lash
- Gloves, a four-in-hand tie, and a flower in the lapel are traditional, but not required

**Saddle**

A saddle seat-type saddle is required. Dressage, hunt type, all purpose, and western saddles are prohibited. Breast collars are optional.

**Bridle & Bit(s)**

A full double bridle (curb and bridoon), pelham, or breed-appropriate bit is required. Martingales and tie-downs are prohibited.

## **Contest Guidelines**

---

**Show Classes**

Any or all of the classes listed in this guide may be offered at a show or fair where 4-H classes are conducted. At pre-fairs, county fairs, or any state qualifying event, showmanship is required.

**Class Priorities**

When management must choose between equitation and pleasure classes, equitation classes must take priority. For example, western equitation and bareback equitation must be offered before western pleasure. If entries warrant, saddle seat or hunter seat equitation must be offered before english pleasure classes. If entries warrant, it is recommended that all shows offer at least 2 equitation classes and a showmanship class; for example, western equitation, bareback equitation, and showmanship.

**Ribbons and Awards**

4-H uses the Danish system of awards in which every contestant receives an award: a flat blue, red, white, or participation ribbon. Trophies, rosettes, and other special recognition may be awarded in addition.

The standard breakdown for ribbons is blue award, 85–100; red award, 70–84; white award, 69 and below. Disqualified riders may receive a white or participation ribbon. The system may also be modified in classes that do not follow the same 100-point system or scoring criteria. These classes may include dressage, trail, and western games.

**Participation**

Show management may invite participation from 4-H clubs outside the county or limit participation to 4-H members from its own county. This should be stated on the entry form.

# Performance Guidelines

## Showmanship

### Scoring

100 points total

### Member

Neat and clean, properly dressed, prompt and alert, confident (poised), courteous ..... 25%

### Animal & equipment

Animal clean and brushed, in good condition, feet cared for. Halter and lead fitted, equipment clean and safe..... 25%

### Showing the animal

Following directions, leading, turning, standing, backing, stopping, showing to advantage, controlling on lead and in line..... 50%

The purpose of showmanship is to teach courtesy, good grooming, poise, confidence, and how to fit, train, and handle your horse. Showmanship is a demonstration of the member's ability to show the animal, in hand, to its best advantage. Conformation of the animal is not considered.

Attire may be western or English. Driving attire is also allowed except for skirts or dresses.

The type of headgear for the exhibitor in showmanship is optional. ASTM/SEI helmets, although not required for showmanship, are encouraged. Either an appropriate hat or helmet must be worn.

### Showmanship Equipment

The horse may be shown with a safe, properly fitted halter or show bridle, each complete with a throatlatch. Bridles may be used when appropriate to breed and/or attire. If you show with a double bridle, you may use either the snaffle or curb reins for leading. The other set of reins is put over the neck near the withers. The halter and lead should be leather, rope, or webbing. The lead should be 6–10' (about 2–3 m) long. Be sure the lead is long enough to allow picking up a hind foot.

If used properly, lead shanks with chains attached are permissible for safety or control. A chain approximately 15–24" is long enough. The chain may be run through the ring on the side of the halter or through the ring on the bottom, then over the nose or under the chin to the other side. With a very long chain, you may run the excess up the off cheek. If your chain is too long, it may be doubled back through the bottom ring and snapped back to itself. In all cases, the snap should face out. When leading your horse, do not put your hand on the chain. Whips and/or bats are not allowed.

**Western tack.** Horses must be shown in a halter.

**Hunt seat or saddle seat tack.** Horses may be shown in a halter or show bridle when appropriate to breed and/or attire.

### **Class Procedure**

Enter the arena as directed by the judge, ring steward, or announcer. Keep at least 1 horse length behind the horse in front of you. If necessary, pass on the inside and return to the rail. The exhibitor should be aware of the judge's position at all times.

The member should walk ear-to-ear with the horse, about an arm's length from the near side. Hold the lead 8–18" from the halter in the right hand with the end folded in a figure-8 in the left hand. Do not coil the lead or fasten it with a rubber band in a figure-8.

If instructed to line up, do so side-by-side leaving 6–8' between horses if possible. This allows the judge to pass safely between horses and to have a good view of your horse. Quickly stand the horse square, balanced or stretched, consistent with the breed and your attire. While in line, do not let your horse circle you. Always turn the horse away from you for turns 90 degrees or more (quarter turn).

If asked to move to another position in line, back out quietly and promptly lead to the new place. Speak to the animal to prevent it from becoming startled when another horse is moved nearby.

Pose (set up) your horse with all 4 feet square or according to breed type. The horse's head should be up and its weight should be on all 4 feet. Do not let the horse "go to sleep," but do not do anything that will attract attention. A gelding may "let down" when standing relaxed; correct by moving him forward or back. You should not use your feet to touch the horse's hooves to get it to set up, nor should you change hands on the lead to set up. If the horse moves out of position, quickly reset it. Quiet voice commands may be used.

When the horse is set up, the exhibitor should face the horse diagonally at a 45 degree angle off the horse's shoulder in front and to the side of the head, moving from side to side as necessary. Be in a position to see your horse and keep eye contact with the judge without blocking the judge's view or standing directly in front of your horse.

When the judge inspects your horse, respond to his or her movements with the quartering system by mentally dividing the horse into 4 quarters. When the judge is in the right front quarter, you are on the left front quarter of the horse, keeping an eye on the judge. When the judge is in the back right quarter, you are in the front right quarter watching the horse. The objective is for you to be in the quarter next to the judge's position.

Change sides when the judge is at the heartgirth and when the judge crosses the tail and the nose. You should step around the horse's head quickly and quietly, using 3 or 4 steps and keeping eye contact with the judge. Do not change hands on the lead when you change sides, and never stand in front of your horse in the "danger zone."

Listen carefully to instructions. When asked for your individual performance, follow the judge's instructions. Be ready to move promptly when signaled. Lines should be straight, and you should remain 5–7' away from the judge. Haunch turns and forehand turns should have forward motion. Turn the horse away from you if the turn required is 90 degrees or more. For turns less than 90 degrees, you may turn the horse toward you.

To back, face to the rear of the horse. In **Washington and Idaho**, do not change hands on the lead to back. In **Oregon**, changing hands on the lead is optional. Back the horse the requested distance in a straight line. Four steps are considered 1 length, counting the movement of the front feet. If the pattern includes "closing the back," return to your position at the start of the back and balance your horse.

Exhibitors may touch their horses only when requested to perform sidepass or forehand turn maneuvers (or to smooth the mane or forelock). This means you must not touch your horse when asking for a haunch turn or back, nor pet your horse until the class is dismissed.

### **Judging Requirements**

Horses should be well-groomed, clean, and clipped according to breed. The horse should also be well-trained to the required routine and well-mannered so that it stands quietly, but alertly, while in the class.

Exhibitors will be asked to demonstrate their ability to lead, turn, set up, and move their animals as the judge requests. Additional tests, as listed, may be asked.

The following principles always apply:

- Individual tests must be performed with official(s) involved in the same relative position to each exhibitor.
- The exhibitor shall not stand directly in front of the horse.
- The quartering system is required.
- Horses may be shown, trimmed, and groomed according to breed type.
- The exhibitor shall not touch their horse except when executing a requested test that allows such touch (for example, sidepass and turn on the forehand), and to smooth the mane or forelock if the judge's inspection has disturbed the grooming.

### **Tests**

- Back horse.
- Sidepass. The exhibitor may touch the horse.
- Turn on haunches (forward motion preferred).
- Turn on the forehand (forward motion preferred). The exhibitor may touch the horse.
- Lead at the walk or trot from either side.
- Pick up the feet.
- Stop and set up, square and balanced, or according to breed standard. Do not change hands to set up.
- Answer questions from project materials.
- Perform a circle at a walk or trot.

## Equitation

### **Scoring**

100 points total

#### **Member and appointments**

Clothing, equipment, courtesy, poise..... 15%

#### **Seat and hands**

Seat, posture, head, legs, hands, balance, distribution of weight, aids..... 35%

#### **Performance**

Standing, starting, walking, jogging or posting trot, figure-8 or equivalent at lope or canter from walk, stopping, turning, backing, general control .....50%

The horse should do what the rider asks with the least possible effort on the part of the rider and least amount of resistance from the horse.

Gaited horses that pace, slow gait, fox trot, singlefoot, rack, or perform a running walk may be worked with the class, adjusting their speed to conform to the other horses. When riders are asked to post the trot on the rail or in a pattern, the intermediate gait is acceptable if that is the breed standard. However, if all other aspects of the performance are equal, a rider posting correctly will be given preference.

The member will be judged on correct posture, smooth gait transitions, and effective use of aids, with special emphasis on light hands. The performance of the horse is not to be considered more important than the methods used by the rider in obtaining the performance.

The member, horse, and equipment may be inspected at any time during the contest. Members using unsafe equipment may be asked to leave the ring.

### **Class Procedure**

Enter the arena to the right in a counter-clockwise direction. Exhibitors will be asked to walk, jog, trot, intermediate gait, or canter/lope both ways of the ring as instructed. Stay on the rail unless it is necessary to pass a slower horse; pass on the inside, toward the center of the arena, and return to the rail. All gaits are required in both directions UNLESS a pattern follows. Saddle seat riders may reverse to the outside.

The show committee or judge may ask for all or part of the tests listed. The patterns may be posted. In addition, the judge may ask for advanced movements and/or questions from 4-H horse project materials.

## **Tests**

- Regular or extended walk.
- Regular or extended jog, trot, or intermediate gait (in western riding at the extended jog, the rider should lean slightly forward, keeping contact with the thighs, with more weight in the stirrups. The seat should come slightly out of the saddle.)
- Lope or canter (on the correct lead or a counter canter).
- Perform figure-8s, serpentines, circles, straight lines, or other specific pattern at any of the above gaits.
- Simple, interrupted, or flying lead changes.
- Ride without irons or stirrups and drop and pick up irons/stirrups.
- Haunch or forehand turn (forward motion preferred).
- Sidepass or 2-track.
- Transition from any gait to halt followed by “on the buckle” or loose rein.
- Change of diagonals.
- Pick up the reins (saddle seat only and only in line).
- Back up.
- Stand for inspection.
- Rollbacks (western only).
- Mount and dismount (juniors may NOT be asked to mount).
- Balanced stops.
- Answer questions from project materials.

## **Bareback Equitation**

Exhibitors may be asked to perform any test listed in equitation. Western riders must sit the jog or intermediate gait. English riders must post the trot on the correct diagonal. No mount or dismount is allowed.

## **Hunt Seat Equitation over Fences**

A horse should be at least 5 years old before going over jumps.

### **Performance**

Any test listed under equitation may be asked. Performance will be judged on effective use of aids on the entire course. Emphasis will be on light hands, balance, correct posture, and seat on the flat and over fences. Excessive speed will be penalized.

Before taking any jumps, including the warm-up jump, a safety inspection should be done. The inspection will include, but is not limited to, making sure the stirrup bars are open, the stitching on saddle stress points is in good repair, the girth is snug, and the bridle is properly fitted and in good repair.

Recommended jump heights:

2' 3" for Juniors

2' 6" for Intermediates

2' 9" for Seniors

Jump height is not to exceed 3', and the spread is not to exceed the height.

A **supervised** warm-up jump must be available prior to the class. This warm-up should be limited to 1 jump, preferably not on the course or inside the arena or pattern area. The number of times a competitor can practice the warm-up jump is to be specified by the local show committee.

The course will consist of 6–12 jumps, performed at a canter, with at least 1 change of direction. The judge may ask the class to do rail work at a walk, trot, and canter both ways of the ring.

The rider will be allowed to circle **1 time** before starting the course. A refusal will be called when a horse avoids a jump or stops forward motion. If the refusal is at a combination jump, the rider must retake all elements of the combination. Faults such as knock-downs and touches will not be considered unless they are the fault of the rider.

### **Types of Fences**

Basic types of fences are allowed; for example, post and rail, wall, gate, brush, coop, planks, and picket fences. Spreads should not exceed the height of the fence. Wings at least 12" higher than the jumps and 30" wide are compulsory when jumps are less than 12' wide. The distance between standards should be a minimum of 9'. Ground pole or lines are required. Courses should have at least 4 different types of jumps and 1 combination jump (24 or 36' apart); in and outs are not to be used at the start of the course. Use of striped rails is discouraged. Triple bars, hogs backs, targets, square oxers, hinged chicken coops, and any bizarre or dangerous jumps are prohibited.

**Table 1. Major faults and disqualifications in hunt seat equitation over fences**

<b>Major Faults</b>	Refusal(s) Loss of stirrup Trotting while on course Loss of reins Excessive speed Lack of control
<b>Disqualifications</b>	Fall of horse or rider 3 cumulative refusals Off course

## Dressage

### **Performance**

Test requirements are the same for juniors, intermediates, and seniors. Tests are to be ridden and judged according to USEF dressage rules except where noted in this contest guide. Tests to be used are the current approved USEF tests, which are usually updated by USEF every 4–5 years. Exhibitors should make sure they are using the most current test each year. Test reading must be limited to 1 time for each movement.

At any given show, only the first dressage test ridden is officially scored. For learning purposes, a second test can be ridden if it is different from the first, but it will not be scored.

*Example: A 4-H member cannot ride Training Level-Test 2 more than once, but they could ride Training Level-Test 2 for a score and then First Level-Test 1 for added experience.*

A ride is to be judged on the horse's gait, impulsion, and submission; the rider's position and seat; and the correctness and effectiveness of the aids. Each movement is scored (0–10 points) to establish whether it was insufficient (4 or below) or sufficient (5 or above). Additional information on how to ride the test and how the test is to be judged can be found in the *4-H Dressage Manual*, PNW608.

## Trail

The trail class is an under-saddle mounted test of horse control and the rider's ability to guide the horse through a series of obstacles. The course must be safe for horse and rider. The obstacles may be progressively harder for each age group.

The course should not be spread out over a very large area; obstacle spacing must allow the horse to move easily between obstacles with no wasted time. The course should be designed to be completed in less than 5 minutes. Riders may be asked to move on at the judge's discretion or after 3 refusals.

The rider may show English or western. See clothing and equipment specifications for proper tack and attire. Riders moving on to championship classes must ride the same seat as in the first class.

Courses must be posted showing the order and direction of the obstacles. Measure and reset each disturbed obstacle for the next rider. Courses will contain 6–10 obstacles and be typical of items members might encounter on a regular trail ride. See Table 2 for obstacles and suggested spacing. Obstacles may be used individually or in combination.

Unsafe or unnatural items are not permitted, such as stepping into tires, water box with floating or moving objects, fire extinguishers, and cinder blocks.

Each obstacle has a value of 10 and is scored according to how the rider maneuvers through the entire obstacle. Judges should give credit for any positive action. The course may be scored by 1 judge or divided between 2 or more judges, with each scoring specific obstacles.

**Table 2. Mandatory Dimensions of Trail Obstacles**

<p><b>Walk/Trot/Lope-Overs</b>            Single poles            Multiple poles</p>	<p>Maximum height 16"            Maximum height 10"             Set 20–24" apart for walk-over            3–3.5' apart for the jog            6–7' apart for the lope/canter             Spoke style should be set 24" apart halfway out from center             No rolling poles allowed</p>
<p><b>Back-Throughs</b>            On ground            Elevated            Barrels</p>	<p>Minimum of 28" wide            Minimum of 30" wide            Minimum of 32" wide</p>
<p><b>Sidepass</b>            Single pole up to 24" high</p>	<p>Space between poles 24" minimum of</p>
<p><b>Serpentines</b> (jog-arounds)</p>	<p>Pylons 6' apart (base to base) minimum            Guardrails 3' to either side of pylons             Pylons 3' apart (base to base) minimum            Guardrails 6–8' to either side of pylons             If tall standards are used, dimensions can be looser</p>
<p><b>Gate</b></p>	<p>Latching between 54 and 60"            Minimum of 48" wide            Rope gates optional</p>
<p><b>Bridge or Plank</b></p>	<p>Minimum of 36" wide for a bridge            Minimum of 12" wide for plank placed flat on the ground</p>
<p><b>Ground Tie or Hobble</b></p>	<p>Inside a minimum of a 6' circle</p>
<p><b>Mailbox</b></p>	<p>Must be a minimum of 48" from ground to the bottom of the mailbox</p>
<p><b>Obstacles <i>NOT</i> allowed</b></p>	<p>Tires, walking on plastic, cinder blocks, fire extinguishers, water boxes with floating or moving objects, unsafe or unnatural obstacles</p>
<p><b>Other obstacles you may want to consider</b></p>	<p>Tie horse properly, pick up horse's feet, dismount and mount (juniors will not be asked to mount), walk through brush or by an animal, hide, or noisy object</p>

# **Driving**

## **Appointments**

### **Animal**

A single horse, pony, miniature, mule, or donkey may be driven. Classes may be divided into 4-H member age groups and/or by the size of the animal. Care should be taken that the animal is not asked to pull too much weight (see *4-H Driving Manual*, PNW 229, for specifics). When determining animal height, allow an additional ½" if shod. Natural gaits are desirable. Chains are prohibited. It is permissible to stretch or park your horse if breed and turnout are appropriate.

### **Attire**

Attire should be neat, clean, and well fitted. Approved headgear, riding boots or sturdy leather shoes, gloves (may be black or brown, but brown is traditional), and a driving whip are required. English or western riding attire is acceptable.

Additional options and restrictions for attire are noted below.

**GENTLEMAN**—Sport coat and slacks or suit (western cut acceptable). A driving apron is optional.

**LADY**—A long-sleeved shirt/blouse with jeans, slacks, or an ankle-length skirt. A vest or jacket may also be worn. Dresses and eveningwear are not acceptable. A driving apron is optional.

**HEADER**—Hard-soled shoes or boots, a long-sleeved shirt, and jeans or slacks. If the header is a 4-H member, approved headgear is required.

### **Vehicle**

An appropriate 2- or 4-wheeled vehicle is allowed. The vehicle must have a footrest or basket (a minimum of 10" front to back) securely fastened to the vehicle. The basket must be constructed so the driver's feet cannot get stuck. Racing sulkies or roadster bikes are prohibited. Shafts should be equipped with a single tree or trace hooks. The vehicle should be in safe, useable condition and should fit the animal to which it is attached.

### **Harness**

A leather or synthetic pleasure-type harness is acceptable. **For safety reasons, a nylon harness is not recommended.** The harness must be in safe, useable condition and must fit the animal wearing it. The reins must be either buckled or stitched together.

*Required* pieces of harness are:

- Crupper
- Either thimbles or breeching
- Either wrap straps or overgirth
- Blinders
- Cavesson/Noseband
- Snaffle or driving curb bit

**Twisted wire and gag bits are NOT permitted.**

*Optional* pieces of equipment are:

- Overcheck or sidecheck
- Running martingale
- Kicking strap (recommended)
- Support boots, quarter boots, splint/brushing boots

### **Whip**

A driving or buggy whip is required and should be carried in the right hand. A longeing-type whip is not permitted.

### **Safety**

Any entry the judge feels is unsafe may be dismissed whether due to turnout or behavior of the animal. Management should permit only the number of entries that can be shown safely at one time for the size of the ring. Age divisions may be combined if classes are small.

Extreme speed will be penalized. Pass other vehicles on the inside, watching the traffic. Avoid cutting back to the rail immediately in front of another driver.

One properly dressed intermediate, senior, or adult header is required for each driver in the lineup. The header should enter the arena once all the entries have lined up and permission to enter has been granted. The header should not touch the animal except in case of a potential emergency.

In case of a runaway, all other drivers are to move off the rail to the center of the arena and stay in their vehicles. Most frightened horses have a tendency to run the rail looking for a way out.

## **Classes**

### **Reinsmanship**

#### **Scoring**

100 points total

#### **Driver**

Handling of reins and whip, control, posture, and overall appearance  
of the driver..... 35%

#### **Appointments**

Proper harnessing and hitching; condition of horse or pony, harness,  
and vehicle ..... 25%

#### **Performance**

On rail and in pattern ..... 40%

### **Basis of Judging**

Judged as an equitation class on hands, proper harnessing and hitching, and correct driving techniques. The driver should be able to change gaits quickly, smoothly, and unobtru-

sively while always maintaining contact and using correct driving techniques. This class is designed to test the driver's knowledge and ability. A pattern is required. Extreme speed and/or extreme high action due to a horse's length of foot, pads, and/or weighted shoes will be penalized.

### **Class Procedure**

Drivers enter and line up a safe distance apart, with headers, for inspection by the judge. Drivers proceed at the direction of the judge on the rail and work both directions of the ring at a flat-footed walk, slow trot/jog, working trot/jog, and strong trot. The reverse will be executed on a diagonal at a walk or working trot from a designated corner at the direction of the judge or ring steward. Drivers line up according to instructions by the judge or ring steward. Horses must stand quietly in line.

### **Suggested Reinsmanship Pattern Elements**

- Back 4 steps and close the back.
- Drive a circle of specified size.
- Drive a figure-8.
- Drive at a strong trot.
- Negotiate a simple obstacle (i.e., drive between 2 obstacles at a working trot or halt between 2 given markers).
- Pivot (turn) with 1 wheel in place, left or right, at 90, 180, or 360 degrees, at the judge's direction.
- Back between 2 markers.
- Drive at the lengthened flat-footed walk.
- Answer a 4-H driving question posed by the judge.

Patterns may include other elements.

### **Precision Driving**

#### **Scoring**

100 points total

A perfect score of 100 points is based on a maximum of 80 points for a fault-free\* performance and 20 points for reinsmanship and overall smoothness of the performance. Faults are deducted in 5 point increments from the possible 80, while single-point deductions are made from the 20 points.

*Example: A driver incurs 3 faults and receives a score of 13 for reinsmanship/performance. The 3 faults (at 5 points each) total 15 points; which are deducted from 80, resulting in 65 points. Those 65 points along with the 13 reinsmanship/performance points yield a final score of 78.*

---

**\*Faults:** First and second refusal; displacing any marker, hoof, or wheel outside marker; and breaking gait will each incur a 5 point deduction.

**Elimination:** 3 cumulative refusals; receiving outside assistance of any sort; showing an obstacle to the horse; or taking an obstacle out of order (off course)

## Basis of Judging

This competition tests the skill of the driver, the obedience and handiness of the animal, and the accuracy with which the course is driven.

## Class Procedure

All drivers must submit to an inspection by the judge before starting the course. Competitors will be required to drive over a course consisting of 6–8 obstacles. The course will be irregular, necessitating changes of direction. Markers indicating obstacles will be at least 12" wider than the track width of each vehicle (measured from the outside edge of one wheel to the outside edge of the other wheel) and 12" high. (Traffic cones with tennis balls on top work well.) Lanes may be defined by rails at least 3" in diameter. A course may be set up using only cones and tennis balls if other obstacles are not available. For examples of courses, see Sample Precision Driving Courses #1 and #2.

Drivers are required to drive at a trot except where obstacles require halting, backing, pivoting, or very tight turns.

### PRECISION DRIVING COURSES (SUGGESTIONS ONLY)

#### Sample course #1:

1. Enter at a trot.
2. Trot through a 10' square (4 cones).
3. Trot a serpentine of 5 cones (25' apart).
4. Walk with right wheel(s) between poles (6–8" apart).
5. Trot a figure-8 (at least 30' around A and B).
6. Walk with left wheel(s) between poles.
7. Walk a serpentine.
8. Walk into square, stop with front wheels between front cones, back up 4 steps, and return to forward position.
9. Stand quietly until dismissed by the judge or ringmaster.

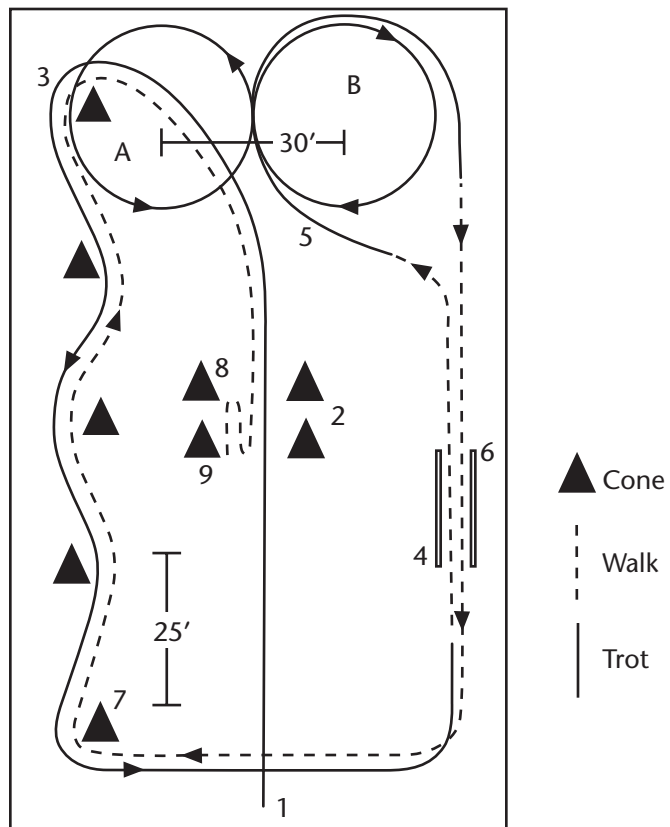

**Sample course #2:**

1. Enter at a trot.
2. Trot through 2 pairs of cones (CDEF, 10' square).
3. Trot a figure-8 (B, then A).
4. Trot a serpentine of 5 cones (25' apart).
5. Walk with right wheel(s) between poles (6-8" apart).
6. Walk to the top of the cone square. Halt with cone C on your left, facing the serpentine. Pivot 90 degrees to the right. Back into the square, between cones C and D, until the cart is between E and F. Halt and stand 10 seconds. Trot back forward through the box.
7. Trot with left wheel(s) between poles and exit.

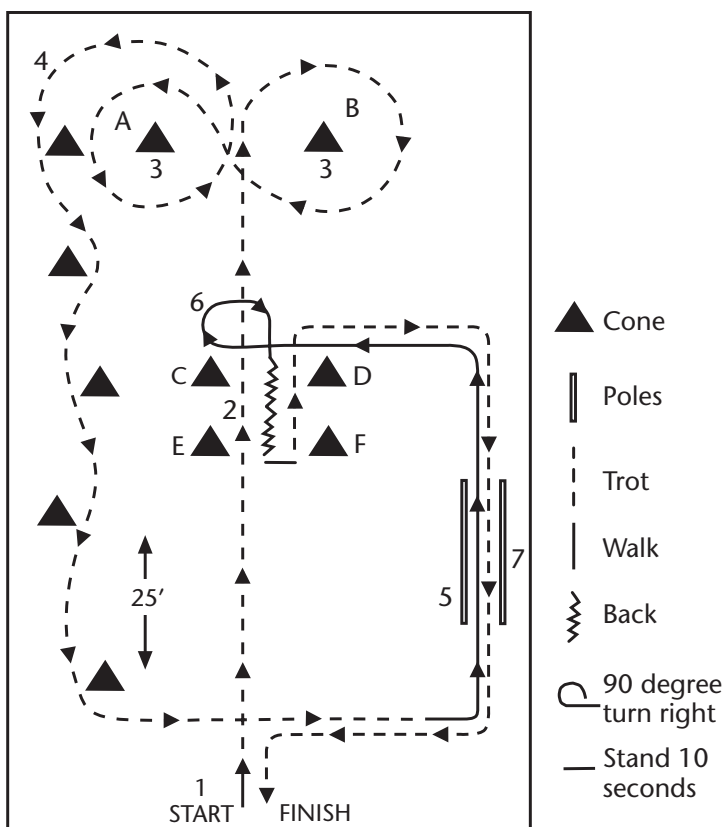

**Pleasure Driving**

**Scoring**

100 points total

**Driver**

Manners, performance, condition, style, and way of going ..... 60%

**Appointment**

Fit, condition, and appropriateness of harness and vehicle ..... 10%

**Performance**

Handling of reins and whip, control, posture, and neatness of driver attire ..... 30%

**Basis of Judging**

The pleasure-driving horse should have the same general qualities as the pleasure saddle horse. Special emphasis is placed on the flat-footed walk and the pleasurability of the ride for the driver. The horse should be in balance with a head and carriage typical of its breed or type, should be light-mouthed, and have a free way of moving. At all gaits, it must work

in form (i.e., head held quietly, mouth closed, and legs working beneath itself). The traces should be steady at all times, demonstrating consistency of forward motion and that the horse is pulling from the traces, not from the mouth or saddle. Erratic movements are highly undesirable. Hesitation or breaking stride will be penalized. Extreme speed and/or extreme high action due to the horse's length of foot, pads, and/or weighted shoes will be penalized.

### **Class Procedure**

Drivers enter and line up a safe distance apart, with headers, for inspection by the judge. Drivers proceed at the direction of the judge on the rail and work both directions of the ring at a flat-footed walk, slow trot/jog, working trot/jog, and strong trot. The reverse will be executed on the diagonal at a walk or working trot from a designated corner at the direction of the judge or ring steward. Drivers line up according to instructions by the judge or ring steward. Horses must stand quietly in line.



### **The E.L. "Dad" Potter Award**

The E.L. "Dad" Potter 4-H horsemanship medal is sponsored in memory of E.L. Potter, Oregon State University professor, expert horseman, teacher, and developer of 4-H horse projects.

Riders may be juniors, intermediates, or seniors enrolled in Oregon 4-H who have passed steps 1, 2, and 3 of the horse advancement program. 4-H members must have owned and/or cared for and personally trained the horse used for at least 6 months.

The trial is a test of finished horsemanship for horse and rider. The horse must be quiet, well-mannered, and under full control. The rider must use seat, hands, and leg aids properly.

The horse must be in good condition and well-groomed. Equipment and the rider's dress must be suitable, neat, clean, safe, and in good condition. Equipment must be either English or western. Spurs, if worn, may be removed between movements.

### **Arrangements**

Arrangements for scheduled trials must be made with the approval of a county agent of the OSU Extension Service and a 4-H leader. This will include the time, place, and acquisition of an approved "Dad" Potter judge as noted on the most recent version of the Oregon 4-H Judges List. Trials approved by non-certified judges who misrepresent their status on the list will have the application rejected when it is sent to OSU for approval. Trials are often held in conjunction with fairs, but this is not necessary. They must be announced early enough so that all interested members have an opportunity to participate. Members may participate in multi-county tryouts. Spectators should be encouraged to attend.

The area in which the trial is conducted should be a minimum of 50 x 100' of smooth, level ground with good footing. The judge should inspect this personally, and the rider and horse should have time to become acquainted with the area. There should be no distractions. If the judge decides that an error is due to outside distractions, the member should be provided a brief time to calm the horse and may repeat the movement without penalty. The rider may select the sequence for each movement and should indicate when it is being started.

The signed form must be presented to the judge before the test begins. The order of movements must be listed in the column on the left side of the score sheet, as the rider wishes, except Number 10 cannot be done first.

### **General instructions to the judge**

Have a measuring tape or device and a watch with a second hand. Keep in mind this is not a dressage test of unified movements; it is a series of individual tests. Riders should be permitted to relax their mounts briefly between tests by making a circle or two, or taking a few steps for better footing or location.

### **General instructions to the rider**

Only 1 error is allowed and it must be corrected, either at once or later during the trial, as decided by the rider. Any additional error will disqualify the 4-H'er. If all movements are completed with only 1 error that was corrected, the member will qualify. Contestants who fail are eligible for future trials, but not on the same day. In case the above requirements are not met to the full satisfaction of the judge, the judge is authorized and instructed to refuse the award.

### **Second award**

If the member is competing for a second "Dad" Potter medal, it must be with a second horse the member has raised and exclusively trained from a foal along with a statement that confirms this.

### **Movements required**

1. Walk forward and backward the exact number of steps indicated by the judge; repeat 2 more times. The rider must specify the **exact way** the steps will be counted (all 4 feet or a specific foot). The number of steps requested may vary for each repeat. Do not count the last half step to bring the feet even. The front feet should be approximately within half the hoof's length of being even at the end of each move. An inadvertent half step in the opposite direction is a fault (i.e., a half step forward when collecting the horse to back).
2. Side step right and left (the number of steps specified by the judge) with at least 12 steps, or 6 crossovers, in each direction (1 crossover is 2 steps); repeat. The forefoot must cross in front of the stationary foot. The hind feet must cross in front or be placed side by side. Balance the horse before changing directions.
3. About on the forehand, a **full 360 degrees** one way and then the other; repeat. The horse may be repositioned before repeating. **The movement must be done with forward motion**, with no backing around the pivot foot (inside forefoot, which may move only within a 24" diameter circle, or 12" radius from the starting point). **The rider must**

**not be asked to place the horse inside a circle drawn on the ground.** The judge will be prepared to measure a questionable distance. Keep forward motion.

4. About on the haunches, a **full 360 degrees** one way and then the other; repeat. The pivot foot must be the inside hind foot and may move only within a 36"-diameter circle (18" radius from its starting point). Keep **forward** motion.
5. Two track at least 3 times in each direction as requested at a walk or trot. The horse's body must be kept straight ahead while tracking at a 45-degree angle. Forward motion must be combined with side motion in a consistent 45-degree line of travel. Allowing the horse to lead with its shoulders, then quarters, is not acceptable. The distance each way must be reasonable and not tire the horse. Two steps of forward motion are allowed before the horse changes direction. The rider should not be asked for an exact number of steps.
6. Start a jog trot from a standing position; repeat 2 or more times. No walking steps are allowed. The **diagonal** feet should come up at the same time to start the 2-beat trot. Proper collection and impulsion are required for a smooth start. Do not post.
7. Post the trot on a straightaway, starting on either diagonal, changing diagonals at least 3 times as requested by the judge; repeat 2 more times. Demonstrate good equitation and smooth changes with no extra bumps.
8. Perform 1 figure-8 at a posting trot (change to the correct diagonal at the trot), then, without halting, execute a second figure-8 at a canter using a simple change of lead. Halt. Execute a third figure-8 at a canter using an interrupted change of lead. Start the canter from the halt, with no walking or trotting steps.
9. Execute 1 figure-8 demonstrating 2 complete flying changes of lead, continuing on to 2 circles to the right (or left). Make a third complete flying change and 2 circles to the left (or right). Halt at starting point. Change of leads may be executed with either the front or rear legs changing first. A delayed half stride in the rear, or disunited change, is not allowed.
10. Starting from a walk and at least 20' from a wall or fence, pick up a canter immediately. Execute 2 complete flying changes of lead on the straightaway. Maintaining the canter, return to the center of the arena and halt. Allow the horse to settle and stand for 30 seconds without moving any foot. The rider will indicate to the judge when the 30-second count should start, and this will be timed with a watch.

The horse must not be canted, or angled, for the lead changes; only a slight leading of the correct shoulder and haunch is acceptable. Trotting steps, a disunited change, resistance by the horse, charging, or unplanned changes are not acceptable.

### **3-step certificate of merit**

The purpose of the 3-step E.L. "Dad" Potter 4-H certificate of merit is to provide an incentive to Oregon 4-H members to perfect and attempt movements 1–10 in the "Dad" Potter Program. This 3-step program is optional for the 4-H member.

The certificate of merit is awarded to 4-H members as they perfect and attempt the movements in sequences of 3 (in any order, e.g., 1, 5, 3; 4, 6, 8; or 7, 2, 10). A certificate and 4-H merit emblem is awarded for the first 3 movements completed. Subsequent movements,

completed in increments of 3, would be recognized by the member receiving a 4-H merit emblem for attachment to the certificate. All instructions, arrangements, and requirements that apply to the “Dad” Potter 4-H horsemanship award will apply to the 3-step certificate of merit with the following exceptions:

1. The 3-step program is NOT designed as a consolation award for members attempting the 10 steps as a part of the “Dad” Potter horsemanship award. Members must decide the 3 specific movements they will attempt prior to the test (e.g., steps 3, 2, and 10 for the certificate).
2. Any 3 of movements 1–10 may be attempted at one time. No errors will be allowed during the trial of 3 movements selected by the 4-H member.
3. Only 3 steps may be completed on a given day. Movements, once completed by the member, cannot be repeated in future sequences. Members cannot compete for a separate second certificate unless they use a horse they have raised and trained from a foal.
4. Once a first certificate is received, different horses may be used to receive future 3-step awards. Exhibitors will only receive a second certificate if they have raised and trained the new horse from a foal. This means the previous 3 steps completed CANNOT be repeated on the same certificate even if it’s a different horse.

Once the 4-H member has completed 9 steps as designated on the certificate, they will be encouraged to try out for the E.L. “Dad” Potter 4-H horsemanship medal, which requires the member to accomplish all 10 movements at one time.

## **Washington State Medals Program**

The medals program in Washington counties is an optional awards program. The value of a medals program is to establish an educational challenge for advanced riders. Gold, silver, and bronze medals may be awarded to intermediate and senior 4-H youth in a variety of classes including western equitation, English equitation, showmanship, hunt seat equitation over fences, driving, trail, and dressage.



Medals are awarded on a pass/fail basis. Riders can do a pattern correctly but still not receive a medal if they have a sloppy pattern or poor equitation. Awarding a medal is completely at the judge’s discretion. When competing for medals, the exhibitor is riding against a standard of excellence.

Standard patterns are available for counties to use on the WSU 4-H Web site. These patterns are recommended for consistency by the PNW horse judges and Washington Equine Committee.

## Ground Training

The intent of ground training is for a 4-H'er to demonstrate training techniques and accomplishments with their young horse. It is important that the 4-H'er exhibiting the animal has personally done the training for the techniques being demonstrated. The horse may have some training by others, but only what is necessary for basic care and handling. For example, a member could show an animal that was halter broke and taught to load in a trailer by someone else, but they could not use those items as part of their demonstration. Instead, they should demonstrate steps they personally provided the training for such as sidepassing, haunch turns, or saddling.



Ground training is open to weanlings, yearlings, and 2-year-olds. Only yearlings and 2-year-olds are allowed at the state 4-H fair. **Animals entered in ground training classes cannot have been mounted at any time.** A ground training animal may also be entered in showmanship but not in equitation or driving.

An enclosed, reasonably quiet area should be provided for this class. A maximum time limit of 15 minutes will be placed on each contestant. No more than 5 minutes will be allowed to bring in and set up equipment.

Each contestant must give the judge, in advance, a ground training score sheet that lists the items to be attempted. The score sheet is available at Oregon county Extension offices and on the Oregon State University 4-H Web site.

Only age-appropriate items from the back of the scoresheet may be attempted. Contestants must attempt a minimum of 3 items and a maximum of 10 items.

Ground training is NOT an in-hand trail course. Minimal equipment (poles, barrels, etc.) should be used. Any obstacles not allowed in trail (walking on plastic, cinder blocks, etc.) are not allowed in ground training. In addition, the judges may eliminate any items they feel are unsafe.

One properly dressed attendant is allowed in the ring with the exhibitor. The role of the attendant is to hold the horse and/or equipment. It is preferred that a knowledgeable intermediate or senior 4-H member performs attendant duties, but an adult may do so if a qualified 4-H'er is not available.

Scoring is based on how well the items attempted are accomplished and whether adequate progress has been made during the time in training.

# **Western Games**

---

## **General Information**

---

The primary purpose of western games is to provide an educational forum in which youth enrolled in the 4-H horse program demonstrate their ability to navigate a prescribed course in the fastest, safest time possible. Gaming events are timed games on horseback and are individual in nature. Approved events include the Figure-8 Stake Race, Idaho Figure-8, Pole Bending, Key Race, Keyhole Race, Texas Barrels, 2-Barrel Flag Race, and NSCA (International) Flag Race. Counties may run other individual events as long as they are as safe or safer, if they have rules from a recognized gaming organization, and if the county agent and state staff person agree in advance. Usually, team events are not appropriate. Rodeo, racing, and bareback gaming events are prohibited.

4-H western games require the humane treatment of all animals entered in state and county competitions. 4-H exhibitors are expected to treat their animals with respect and provide for the animal's continuous well-being through proper feeding, handling, disease prevention, sanitation, and attention to the animals' safety. 4-H officials should be prepared to dismiss 4-H exhibitors who abuse and mistreat their animals.

4-H members must wear their exhibitor number on their back or both sides of their horse at all times while mounted. Horsemanship, sportsmanship, and safety will be stressed in all western gaming classes.

Exhibitors may be asked to submit to a close inspection before any event. The purpose of the close inspection is to demonstrate an exhibitor's ability to handle and control their horse in a safe manner. The close inspection also provides the show management an opportunity to examine the tack and equipment being used by the 4-H member. Exhibitors failing the close inspection will not be allowed to make their scheduled run in that event.

The safety of the exhibitors, horses, and volunteers is the most important aspect of the program.

## **Scoring**

---

4-H members must compete within their appropriate junior, intermediate, or senior age group. The state competition allows only intermediate and senior-aged youth to enter. Participants are timed and arranged in numerical rank order, then divided into predetermined blue, red, and white ribbon groups. This system is referred to as the modified merit system of judging. Individuals will receive a basic score equivalent to the number of seconds (to the nearest hundredth) that it takes to complete the event. Penalty points are added to this score.

## **Recommended Awards**

The Danish system of awarding ribbons is recommended for western games. Counties may also use the American placing of ribbons (1st, 2nd, 3rd, etc.) in addition to the Danish awards. The awarding of ribbons is based on the rider's time in each event.

Each state has its own method for establishing ribbon divisions. Disqualified riders receive white ribbons, participation ribbons, or no award.

## **General Rules**

In **Oregon** and **Idaho**, contestants may not enter the same gaming event more than once, whether on the same horse or another horse. In **Washington**, entries are at county discretion.

Riders may hold onto the saddle horn. Two hands may be used on the reins, and hands may be changed.

### **Clothing & Tack**

Standard 4-H western clothing is required. Belts are optional. A western saddle with a saddle horn is required. Western-type equipment is to be used with the following exceptions: bridles must have a throat latch, running martingales with rein stops, martingales, tie-downs used with breast collar, nosebands, draw reins, splint boots, bell boots, bandages, mechanical hackamores, and gagbits are permitted; whips under 36", bats, quirts, crops, and over-and-unders are allowed. Roping reins or single piece closed reins must be used.

Tying split reins is not allowed. Mecate reins are not allowed. Riders will be disqualified if the judge considers equipment inhumane or dangerous, or if equipment breaks and the rider is unable to safely continue without repairs.

Bats, spurs, and over-and-unders will be open to inspection by the judges. Spurs, if worn, must be Western spurs and used properly. Should these properties be found to be abusive by nature (such as pronged, weighted, or cutting), they shall be banned from use. No warning will be required.

### **Gaming Equipment**

Plastic 55-gallon barrels are recommended. Eight to twelve pounds of water or clean dry sand is recommended as an appropriate filler material. Metal barrels are strongly discouraged. If no other alternative exists, metal barrels must have a protective material (a rubber bicycle tire) placed around the upper, outermost portion of the rim where the barrel could come into contact with the rider's lower leg.

Poles must be 1-1½" in diameter and 75-85" tall. Poles may be white or striped, depending on the event and/or situation. If striped poles are used, they must have 2 stripes, each 3" wide. The first stripe is 1' foot from the top, and the second stripe is 1' from the bottom of the first stripe. All poles must be made of material that will not splinter, such as schedule

40–80 plastic pipe (schedule 80 pipe is the most durable). Pole bases, weighing approximately 14 pounds, should be 6" tall and 14" across and made of black rubber. The total weight of the pole and base should be approximately 16 pounds.

An electronic timer and reader board are recommended. At county qualifying gaming competitions, if an electronic timer is not available, a hand-held stopwatch that measures times to the nearest 100th of a second should be stationed at the start and finish lines of each game.

### Ties

The recommended procedure for breaking ties is a runoff or toss of a coin. In breaking a tie with a runoff, the rider with the slower time takes the next lower position. If there is still a disagreement, the judge's decision is final.

### Mounted Riders

A rider is considered mounted when their knee is over the center line of the horse's back. Riders must remain mounted until the judge's final acknowledgment.

### Re-rides

Re-rides are run after the last rider in that event. Penalties do not carry over from the original ride.

#### Acceptable reasons for re-rides include:

- Timing device failure
- Course obstruction as determined by the judge
- Course measured incorrectly

#### Unacceptable reasons for re-rides include:

- Horse or rider damage to arena equipment
- Failure of tack or participant's equipment
- Horse or rider accident or injury

### Lane Lines

Lane lines are strongly recommended, but not required. When more than 1 course is in use, lane lines are required for safety. Courses are to be centered within each lane. At times they may not be used because of time constraints; however, the right to re-implement the lane lines requirement is reserved.

### Run-out Box

A run-out box may be used. The size of the box is generally 60' to 80' in length, but it may be modified for safety or arena configuration. If a run-out box is used, all 4 of the horse's feet must remain inside the box until the judge's final acknowledgement.

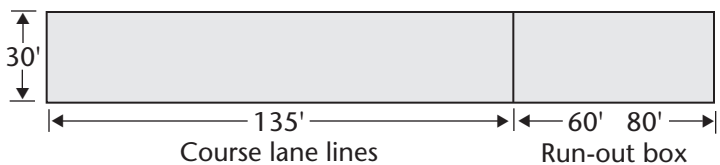

### Moving a Course

If a course is moved for safety reasons, riders may choose to re-ride or keep their first time. If the course is moved because of initial wrong measurement, all riders must re-ride.

### **Acknowledging the Judge**

Riders MUST acknowledge the judge before starting and after completing the course.

Acknowledging the judge is defined as:

- At the start, the rider must control the horse and wait for the judge's signal to begin.
- Before the exit, the rider must have the horse under control, be mounted, face the judge, and wait for the judge's signal to exit.

### **Arena Safety**

- During the running of any event, all arena gates must be closed.
- Contestants must enter the arena mounted in a controlled manner, and may leave the arena only after the judge's final acknowledgment. After the judge's acknowledgment, the exhibitor may dismount, take the reins off the neck for safety, and exit.
- It is recommended that only 1 horse be in the arena at a time.
- Only contestants, ring crew, and officials are allowed in the arena.
- Horses may not be tied to arena fences, rails, or any other hazardous place.
- Horses that constitute a safety hazard may be disqualified.
- In all events the ring crew resets downed equipment or repairs lines after a rider has completed the course.
- Enter the arena without assistance from anyone other than a 4-H member who is also mounted.
- Raking will be done as needed, but must be consistent within each age division.

### **Coaching**

Coaching as defined by show management and at the judge's discretion, is not allowed. It is inappropriate for ring help, announcer, timers, etc., to coach, encourage, or comment to or about exhibitors on the course.

### **Course**

- When a line is used, it means a white line.
- Two poles or cones, 30' apart (60' apart in the case of barrels) designate the start–finish line. A horse must pass between these poles or cones at the start and finish of each event.
- Course measurement is made from the center of the poles, barrels, containers, or other arena equipment.
- Timers are placed on the start–finish line.

### **Penalties & General Disqualifications**

There will be a 5-second penalty for each stake, pole, barrel, or small container knocked down.

Intentionally righting a pole is allowed with no penalty.

Disqualifications include the following:

- Failure to enter the arena mounted
- Failure to enter the arena without assistance from anyone other than a 4-H member who is also mounted

- Failure to cross the start line within 60 seconds from the time the gate opens
- Upsetting the start–finish markers
- Crossing the start–finish line outside of the start–finish line markers
- Run outs
- Refusals (a balk is not considered a refusal if the horse finally finishes the course correctly)
- Leaving the course
- Failure to follow the pattern for the event
- Passing any obstacle completely on the wrong side
- Circling any obstacle while on course, except flag races and other container events
- Failure to keep all 4 feet of the horse from crossing a lane line at the same time
- Failure to keep all 4 feet of the horse inside the run-out box
- A horse being unruly or out of control
- Spurring or striking the horse in front of the cinch
- Striking the horse with arena equipment
- Using rubber bands or anything else to anchor the rider to the horse or saddle
- Failure to acknowledge the judge before and/or after the run

Show management or the judge may disqualify a rider for unsportsmanlike conduct, profanity, unnecessary roughness, abusing their horse, or disorderly conduct of any kind. The judge may also disqualify an unmanageable horse for reasons of safety or the exhibitor's inability to handle or control their horse.

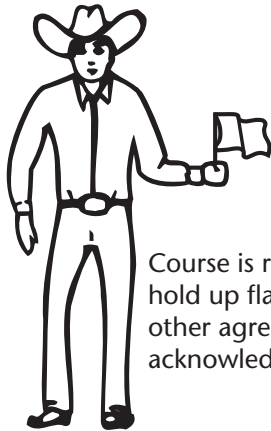

Course is ready—  
hold up flag or  
other agreed-upon  
acknowledgement

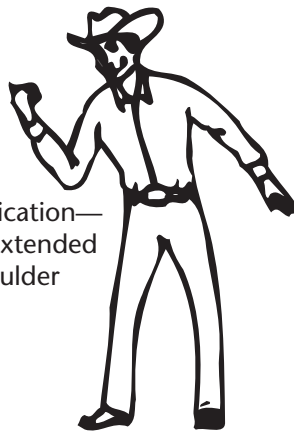

General  
disqualification—  
thumb extended  
over shoulder



Failure to start  
on time—point  
to wrist watch

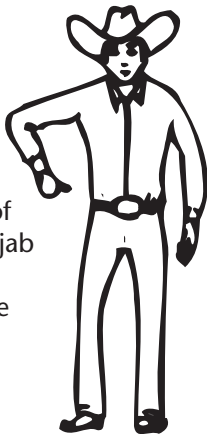

Striking  
ahead of  
cinch—jab  
thumb  
into side

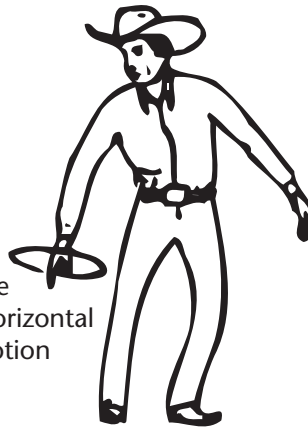

Leaving the  
course—horizontal  
circular motion

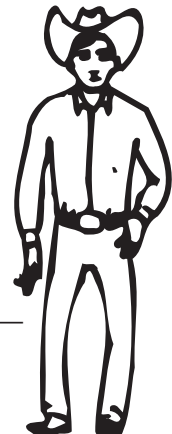

Striking  
the horse  
with arena  
equipment—  
slap thigh

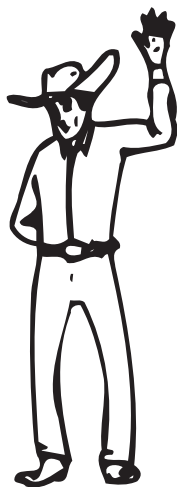

5-second  
penalty—hand  
raised with 5  
fingers extended.  
Repeat to show  
10, 15, or more  
seconds

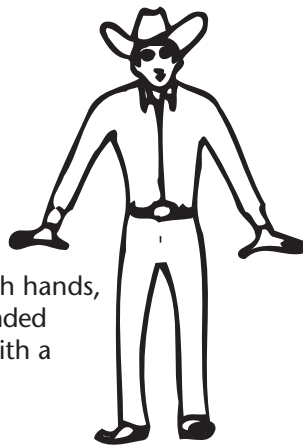

Safe or clean run—both hands,  
palms down and extended  
arm's length in front with a  
back and forth motion



Unnecessary  
roughness  
or abusing  
the horse—  
both thumbs  
to the ribs

## Approved Events

### Figure-8 Stake Race

Two poles set 120' apart at opposite ends of the course, and 2 center poles set 30' apart at a point halfway between the 2 end poles. The 2 center poles mark the start and finish lines. The rider starts between the 2 center poles and runs a figure-8 around the 2 end poles, with the first turn being optional. Riders may start from either end of the course, but may NOT turn a pole on the course before crossing the start line. There is a 5-second penalty for knocking down each pole.

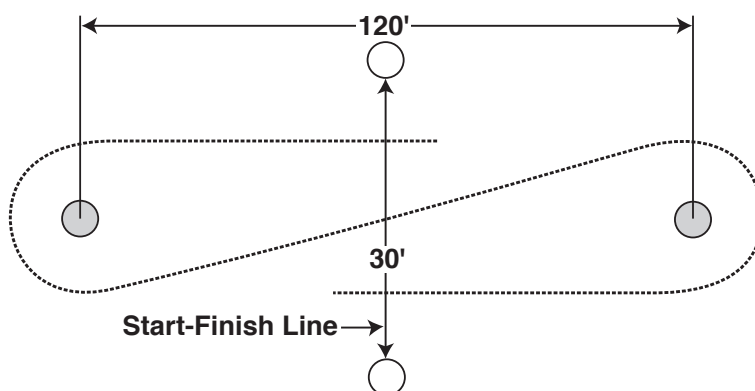

### Idaho Figure-8

Two poles set 100' apart, the first 20' from the start-finish line; the second, 120' from the same line. The rider crosses the start line, rides down the side of the course (side optional) to pole B, turns pole B, rides to pole A, turns pole A in the opposite direction, rides back to pole B, turns pole B in the opposite direction of A, and rides across the finish line, completing a figure-8 pattern.

Riders must remain in designated lanes. There is a 5-second penalty for knocking over each pole. Turning a pole the wrong direction is considered off course.

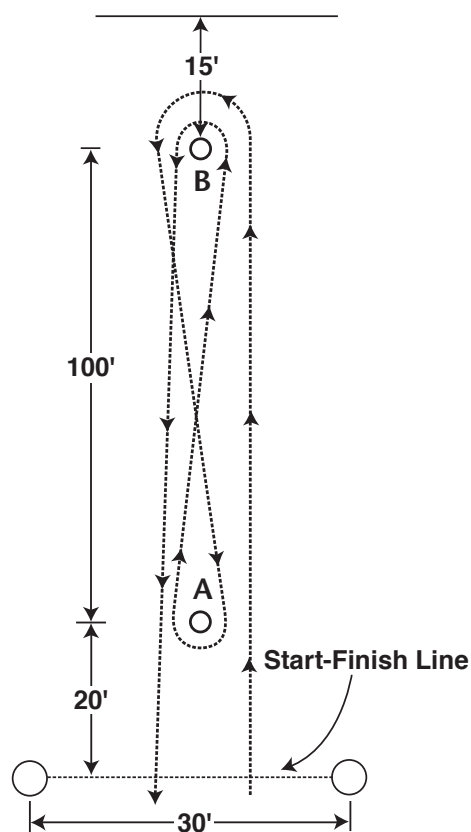

### Pole Bending

Six poles set in a straight line, each spaced 21' apart with the start-finish line 21' in front of the first pole. The rider crosses the start line, travels to pole number 6, bends back through the poles, turns, bends through the poles to number 6, turns, and travels across the finish line.

There is a 5-second penalty for knocking over each pole. Poles will not be set up during the run. Riders must remain in their designated lanes.

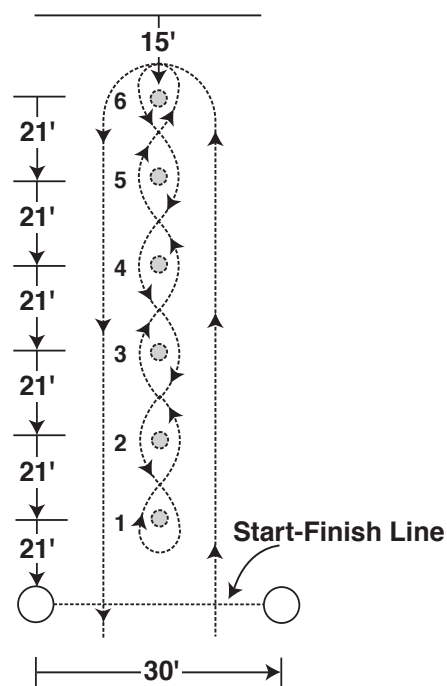

### Key Race

Four white poles, striped or covered with a 48" red sleeve, placed 5' apart at marks 110 and 120' from the start-finish line. The rider travels between the poles across the turning plane, turns, reverses course through the poles, and finishes.

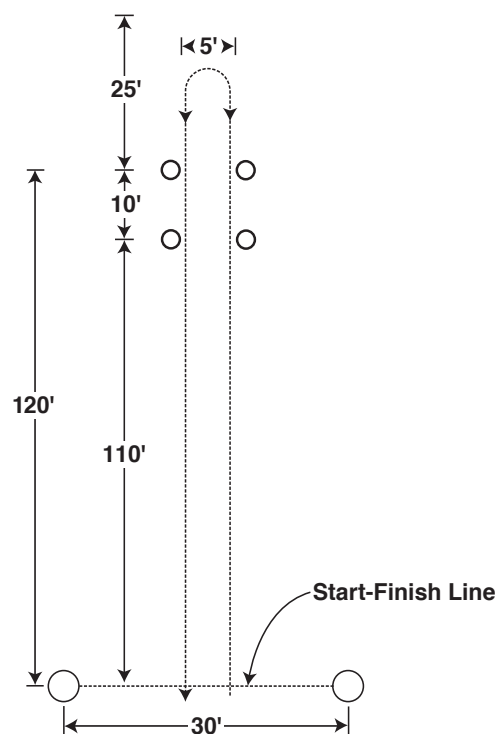

### Texas Barrels

Three barrels placed in a triangular formation. For the 80' course, which can be used in all 3 states, Nos. 1 and 2 barrels are set 33' from the start-finish line and 60' apart. No. 3 barrel is 80' from the Nos. 1 and 2 barrels. For the 75' course, used in Washington only, the Nos. 1 and 2 barrels are set 30' from the start-finish line and 75' apart. The No. 3 barrel is 75' from the Nos. 1 and 2 barrels. Both courses use a 60' start line.

The rider crosses the starting line, circles the No. 1 barrel to the right, crosses to the No. 2 barrel, circles it to the left, rides to the No. 3 barrel, circles it to the left, and travels across the finish line. The rider may alternatively cross the starting line to the No. 2 barrel, circle it to the left, cross to the No. 1 barrel, circle it to the right, run to the No. 3 barrel, circle it to the right, and proceed across the finish line.

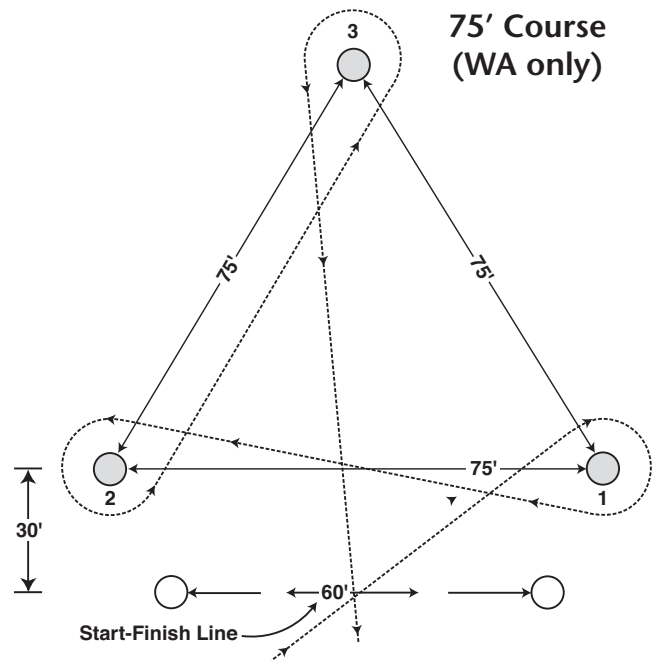
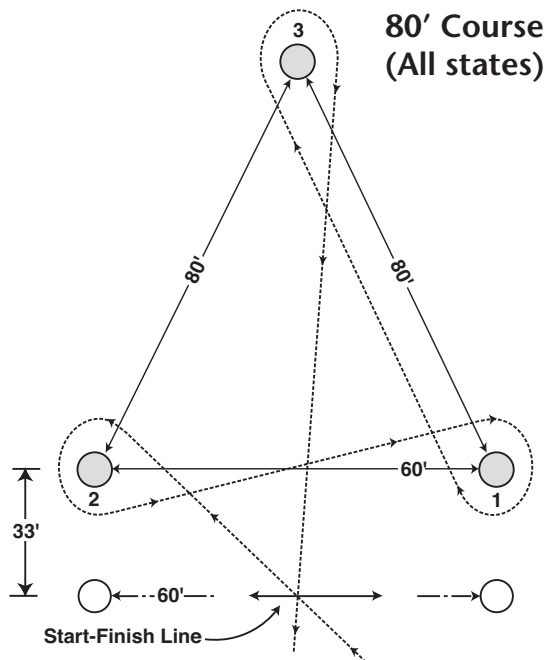

### Keyhole Race

The rider crosses the starting line, travels 100' into a 20'-diameter circle marked with a white line, turns the horse, and returns across the starting line. All 4 of the horse's feet must stay within the circle.

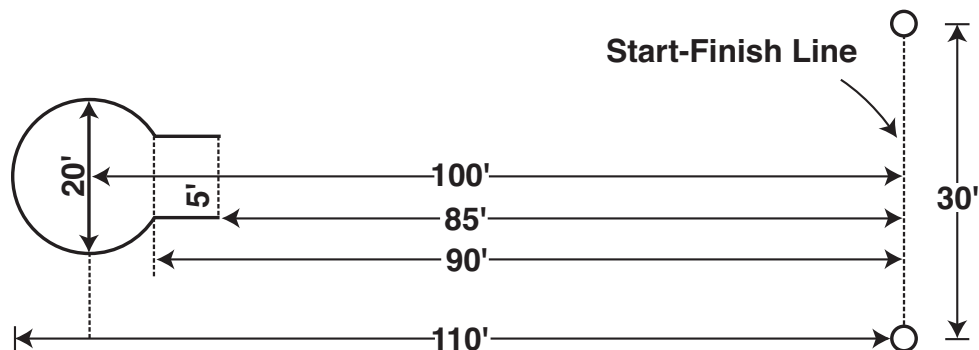

### 2-Barrel Flag Race

Two metal quarter barrels (14" diameter and 27" high), 100' apart, with the first barrel 20' from the start-finish line. The bottom of each container has 8-10" of sand or soft dirt. The staff should be a minimum of 1" and a maximum of 1<sup>1</sup>/<sub>16</sub>" wood doweling, 5' long, painted white. Flags should be a sturdy cotton, hemmed to 8 x 12", one white and one dark. The flags should be wrapped completely around the staff and tacked securely, leaving an 8 x 8" portion free from the staff.

The rider crosses the start line, rides to/past container A (side optional), and takes the flag from container A; then, while riding around container B, the rider places the container A flag into container B and picks up the container B flag; the container B flag then goes into container A as the rider passes; the rider finishes by crossing the start-finish line.

- Riders may designate the flag positions before starting the course.
- A rider may circle either barrel, if necessary.
- A 5-second penalty is added for each knock-down of the container, dropped flag, or missed container.
- A 10-second penalty is added for failure to pick up the flag.
- Riders may cross over between barrels B and A.

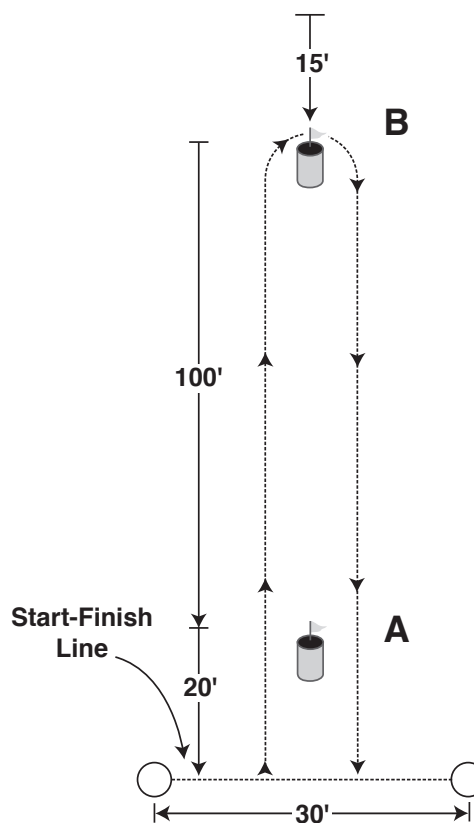

### NSCA (International) Flag Race

A barrel set 120' from the starting line with a 3-pound coffee can filled  $\frac{3}{4}$  full of sand or soil and centered on top of the barrel, a round dowel, 14" long and a minimum of  $\frac{7}{8}$ " in diameter, placed in the can with a flag wrapped and tacked with a 4" square remaining. A rider crosses the start-finish line, goes down and around the barrel in either direction, and carries the flag back across the start-finish line. Knocking over a can is a 5-second penalty. Knocking over a can and barrel is a 10-second penalty. Dropping the flag before crossing the finish line is a disqualification.

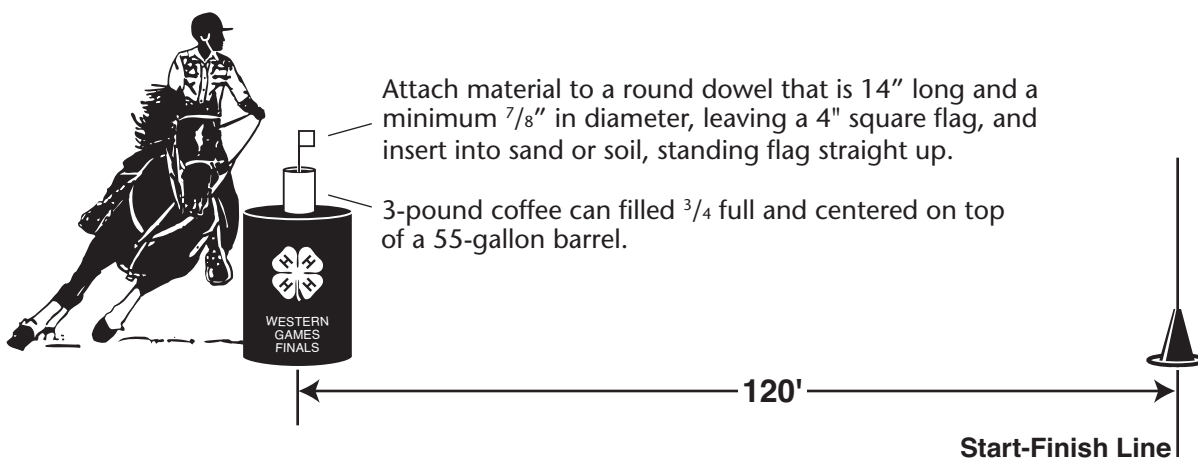

# **Herdsmanship**

## **When Stabling is Available**

All exhibitors are responsible for the care and cleanliness of their own horse and equipment. 4-H members may assist each other, but parents are not to help unless the safety of the child or horse is at stake. The 4-H Herdsmanship Contest encourages 4-H members to make a presentable exhibit for the public and helps develop teamwork, cooperation, and pride. This involves courtesy, cooperation, neatness, safety, and proper care of animals. Leaders and parents are encouraged to give guidance, but members must do their own work.

All materials used in decorations must be fire retardant.

## **Scoring**

100 points total

### **Members**

Appearance (clean and neat), friendliness, courtesy and conduct, cooperation, and positive attitude. All work must be done by members. Boots or fully enclosed shoes must be worn at all times ..... 20%

### **Animal**

Horses are securely and properly tied, clean, and comfortable. No saddled horses should be left unattended in stalls. Horses are safely tied in relation to other horses. Horses are well-groomed and clean. Gates are secure. Water and feed are clean and properly arranged. Stalls are clean. Identification stall cards are posted .... 40%

### **General Club Area**

Club area is clean, neat, and orderly; tack, feed, and other equipment are stored and organized in an orderly and safe manner. The quality of exhibitor decorations and educational information are good. A club banner or sign is used for identification. .... 40%



Pacific Northwest Extension publications are produced cooperatively by the three Pacific Northwest land grant universities: Washington State University, Oregon State University, and the University of Idaho. Similar crops, climate, and topography create a natural geographic unit that crosses state lines. Since 1949, the PNW program has published more than 600 titles, preventing duplication of effort, broadening the availability of faculty specialists, and substantially reducing costs for the participating states.

Pacific Northwest Extension publications contain material written and produced for public distribution. You may reprint written material, provided you do not use it to endorse a commercial product. Please reference by title and credit Pacific Northwest Extension publications.

Copyright 2009 Washington State University.

Order information:

Washington State University Extension

Web <http://pubs.wsu.edu> Fax 1-509-335-3006 Toll-free phone 1-800-723-1763

e-mail [bulletin@wsu.edu](mailto:bulletin@wsu.edu)

Oregon State University Extension Service

Web <http://eesc.orst.edu> Fax 541-737-0817 Phone 541-737-2513

e-mail [puborders@orst.edu](mailto:puborders@orst.edu)

University of Idaho Extension

Web <http://info.ag.uidaho.edu> Fax 208-885-4648 Phone 208-885-7982

e-mail [cking@uidaho.edu](mailto:cking@uidaho.edu)

Issued by Washington State University Extension, Oregon State University Extension Service, the University of Idaho Cooperative Extension System, and the U.S. Department of Agriculture in furtherance of the Acts of May 8 and June 30, 1914. Extension programs, activities, materials, and policies comply with federal and state laws and regulations on nondiscrimination regarding race, sex, religion, age, color, creed, or national or ethnic origin; physical, mental, or sensory disability; marital status or sexual orientation; and status as a Vietnam-era or disabled veteran. Washington State University Extension, The Oregon State University Extension Service, and University of Idaho Extension are Equal Opportunity Employers. Evidence of noncompliance may be reported through your local Extension office. Trade names have been used to simplify information; no endorsement is intended. Revised from EB1974 April 2005. Revised August 2009. Subject code 814.

PNW574